

Model No. JV001G CORDLESS JIG SAW

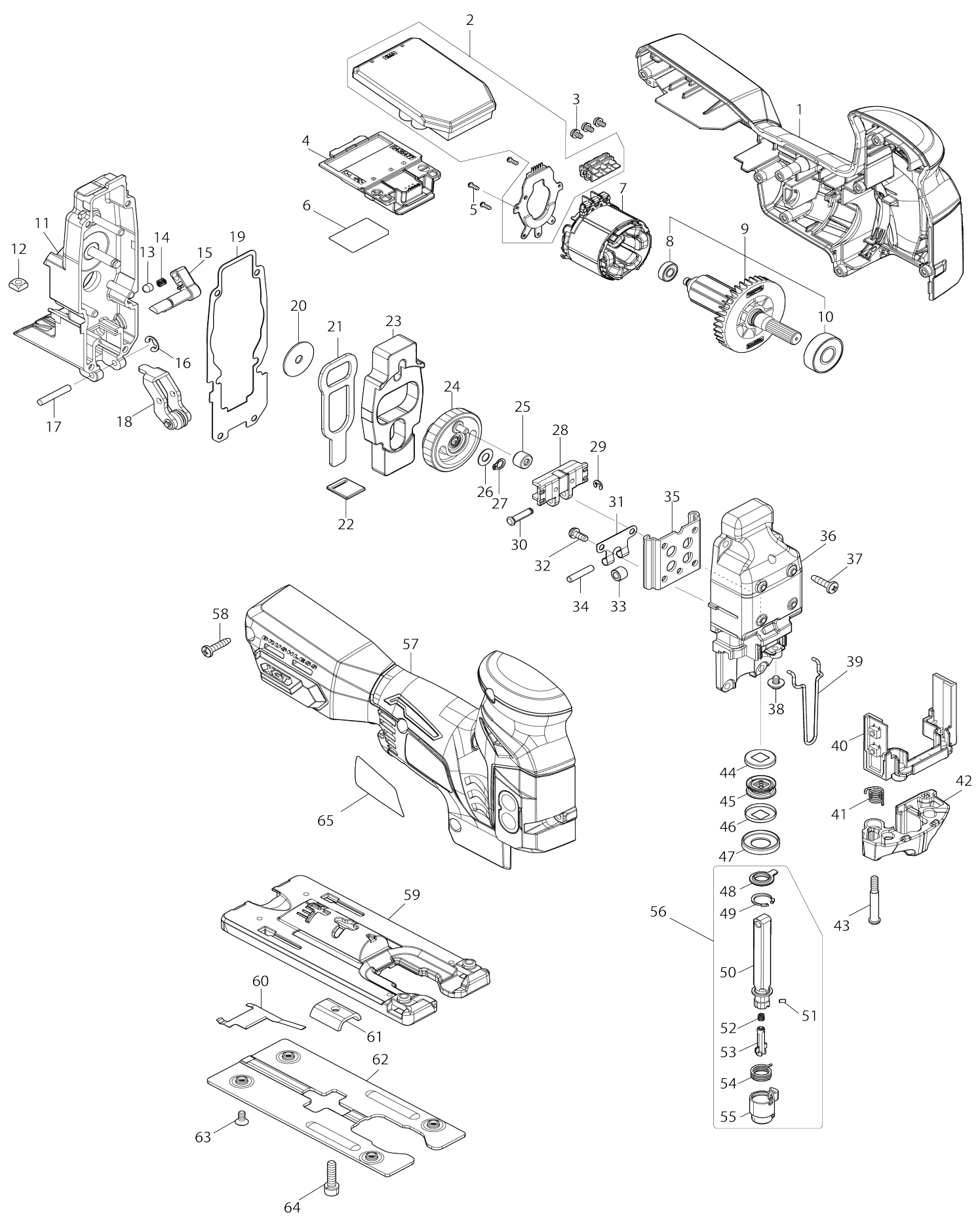

Model No. JV001G CORDLESS JIG SAW

Item No.	Parts No.	Description	Interchangeability	Q'ty	New/Old	Note1	Note2
047-2	141P30-9	WHEEL COVER 180K COMPLETE	<	1			
C10	213017-6	O RING 6		1			
C20	8050A1-8	CAUTION LABEL		1			
D10		INC. 46					
A01	152539-0	GRIP 36 COMPLETE		1	*		
047-2	141P32-5	WHEEL COVER 230K COMPLETE	<	1			
C11	213775-4	O-RING 7	O	1			
C20	8050A1-8	CAUTION LABEL		1			
D10		INC. 46					
A02	782407-9	LOCK NUT WRENCH 35		1	*		
A02-1	197610-3	LOCK NUT WRENCH 35 SET	O	1			
F04	192227-7	SUPER FLANGE		1			
001	183W95-7	HOUSING SET		1			
C10	263005-3	RUBBER PIN 6		2			
C20	8066F9-6	SWITCH LABEL		2			
D10		INC. 57					
002	620J88-0	CONTROLLER		1			
003	652069-6	FLAT HEAD SCREW M3X6		3			
004	632P65-6	TERMINAL UNIT		1			
005	266490-9	TAPPING SCREW PT 2X6		3			
006	858U20-2	JV001G SERIAL NO. LABEL		1			
007	629B64-3	STATOR		1			
008	210039-7	BALL BEARING 695DDW		1			
009	519769-0	ROTOR ASS'Y		1			
D10		INC. 8,10					
010	210059-1	BALL BEARING 6000DDW		1			
011	142111-6	GEAR HOUSING COMPLETE		1			
C10	263002-9	RUBBER PIN 4		1			
012	252171-1	SQUARE NUT M5-8		1			
013	286032-3	CAP 5		1			
014	233139-6	COMPRESSION SPRING 3		1			
015	272280-0	LEVER 17		1			
016	961018-5	STOP RING E-5		1			
017	268063-4	PIN 4		1			
018	142110-8	RETAINER COMPLETE		1			
019	442195-7	GASKET		1			
020	253196-8	FLAT WASHER 6		1			
021	346688-5	PUSH PLATE		1			
022	454484-8	SEAL PLATE		1			
023	313260-8	BALANCE PLATE		1			
024	142109-3	GEAR COMPLETE		1			
025	212092-9	NEEDLE BEARING 407		1			
026	253715-0	FLAT WASHER 6		1			
027	961002-0	RETAINING RING S-6		1			
028	310837-0	SLIDER		1			
029	961017-7	STOP RING E-3		1			
030	268090-1	PIN 4		1			

031	232207-2	LEAF SPRING		1		
032	911111-5	PAN HEAD SCREW M4X10 WITH W		4		
033	214031-5	PLANE BEARING 4		1		
034	256117-9	PIN 4		1		
035	347B50-9	LINEAR GUIDE		1		
036	141R27-0	GEAR HOUSING COVER COMPLETE		1		
037	266034-5	TAPPING SCREW CT 4X16		4		
038	911104-2	PAN HEAD SCREW M4X6		1		
039	326302-9	SAFETY WIRE		1		
040	620J89-8	SWITCH UNIT		1		
041	231659-4	TORSION SPRING 6		1		
042	454483-0	TOOL OPENER		1		
043	265026-1	+ PAN HEAD SCREW M4		1		
044	267854-0	CAP WASHER 8		1		
045	421815-6	DUST SEAL 8		1		
046	267854-0	CAP WASHER 8		1		
047	257347-5	RING 21		1		
048	424569-4	DUST COVER		1		
049	962063-3	RETAINING RING R-13		1		
050	165724-6	ROD		1		
051	256528-8	PIN 2		1		
052	233314-4	COMPRESSION SPRING 4		1		
053	310485-5	LOCK PIN		1		
054	233591-8	TORSION SPRING 10		1		
055	310547-9	BLADE HOLDER		1		
056	135602-4	ROD ASS'Y		1		
D10		INC. 48-55				
057	183W95-7	HOUSING SET		1		
C10	263005-3	RUBBER PIN 6		2		
C20	8066F9-6	SWITCH LABEL		2		
D10		INC. 1				
058	265995-6	TAPPING SCREW 4X18		8		
059	312D19-4	BASE		1		
060	232208-0	LEAF SPRING		1		
061	345237-5	CRANK PLATE		1		
062	347A23-6	BASE PLATE		1		
063	265085-5	+ COUNTERSUNK HEAD SCREW M4X8		4		
064	922231-0	HEX. SOCKET HEAD BOLT M5X20		1		
065	858U14-7	JV001G NAME PLATE		1		
A01	122C71-6	DUST NOZZLE ASSEMBLY		1		
C10	213023-1	O RING 4		1		
C20	265772-6	THUMB SCREW M5X15		1		
A02	413J99-0	COVER PLATE		1		
A03	415524-7	ANTI-SPLINTERING DEVICE		1		
A04	783202-0	HEX. WRENCH 4		1		
A05	A-85737	JIGSAW BLADE NO.B22		1		
A06	A-85628	JIGSAW BLADE NO.B10		1		
A07	A-85793	JIGSAW BLADE NO.BR13		1		
F01	194416-0	SHEET 10000 SET		1		

F02	194417-8	RUBBER SHEET 10000 SET		1			
F03	194418-6	POSITION SHEET 1400 SET		1			

Please state Parts No. when your order.

Print Date 12/15/2023